



INTERNATIONAL TRANSPORTATION OF OVERSIZED AND HEAVY CARGO

Solving large-scale challenges!

ng-negabarit.com



01 TRANSPORT OF OVERSIZED AND HEAVY CARGO

We transport any oversized and heavy loads safely and on time

02 ROUTE SURVEY AND DEVELOPMENT

We analyze routes and select the optimal path for each cargo

03 CUSTOMS CLEARANCE

We process all necessary documentation for border crossing without delays

CARGO INSURANCE DURING TRANSPORT

We insure third-party liability for peace of mind at every stage of the journey

OBTAINING SPECIAL PERMITS

We secure all permits required for the safe transport of oversized and heavy cargo

MULTIMODAL TRANSPORT

We combine different modes of transport for optimal delivery



PROJECT LOGISTICS

We organize complex solutions for the delivery of project cargo of any complexity and configuration

HIGH-VALUE CARGO TRANSPORT

We transport valuable cargo with enhanced security and control

PILOT CAR ESCORT

We control movement and safety on every section of the route using escort vehicles

OUR CAPACITIES FOR YOUR CHALLENGES

- 1 OPEN FLATBED TRAILERS**
Load capacity up to 22 tons, 3 axles
- 2 LOWBOY TRAILERS**
Грузоподъёмность от 45 до 100 тонн, 4–8 осей.
- 3 MODULAR TRAILERS**

SEMI-TRAILERS:

FAYMONVILLE, KASSBOHRER, GOLDHOFER,
ТВЕРЬСТРОЙМАШ, NOOTEBOOM, BROSHUIS,
MAXTRAILER, TSR, GUOSHI HUABANG, HYST

SEMI-TRACTORS:

VOLVO, MAN, SCANIA, DAF, RENAULT, SHACMAN



ENGINEERING TRANSPORT SOLUTIONS

We select equipment and configurations based on weight, dimensions, and route

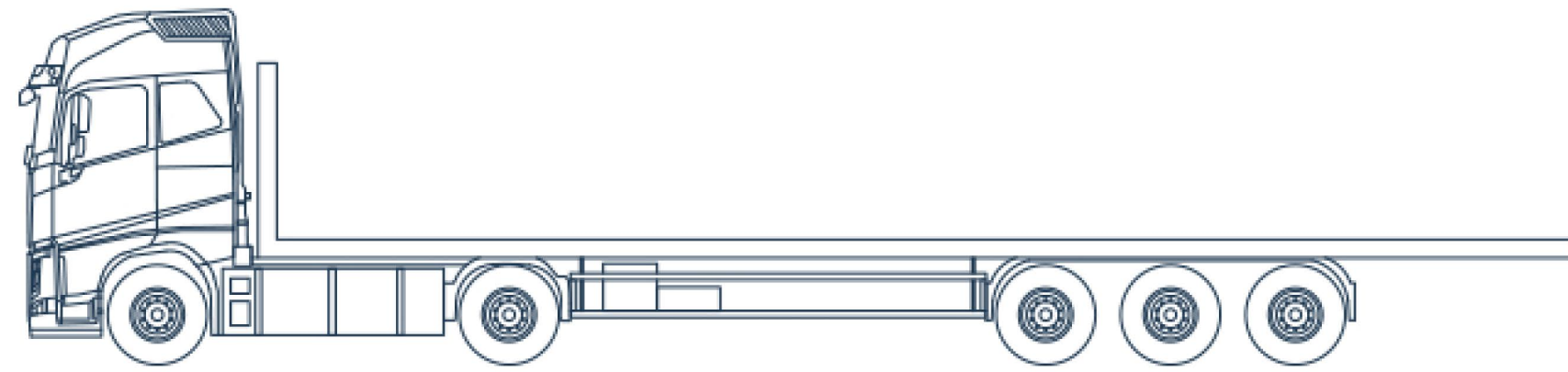

3-axle open flatbed

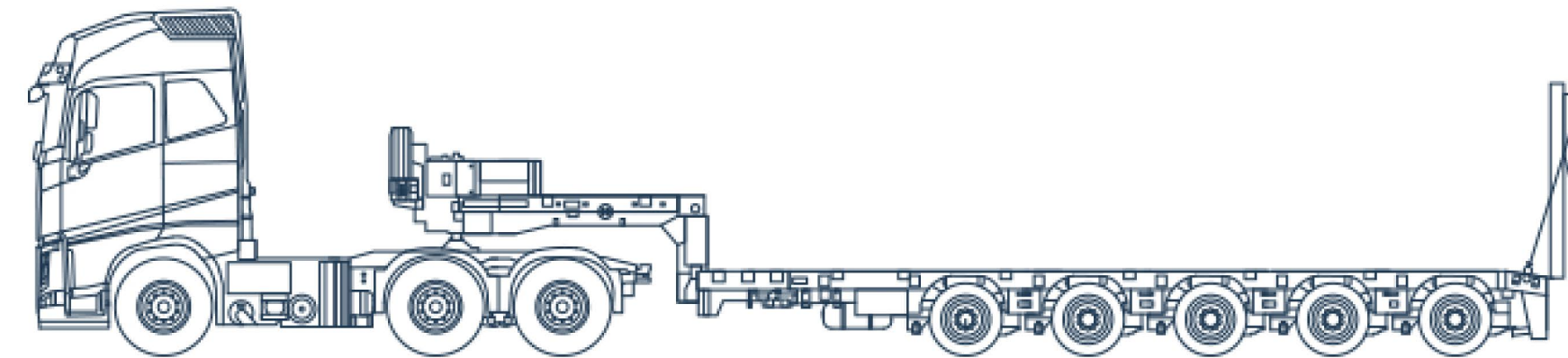

5-axle lowboy trailer

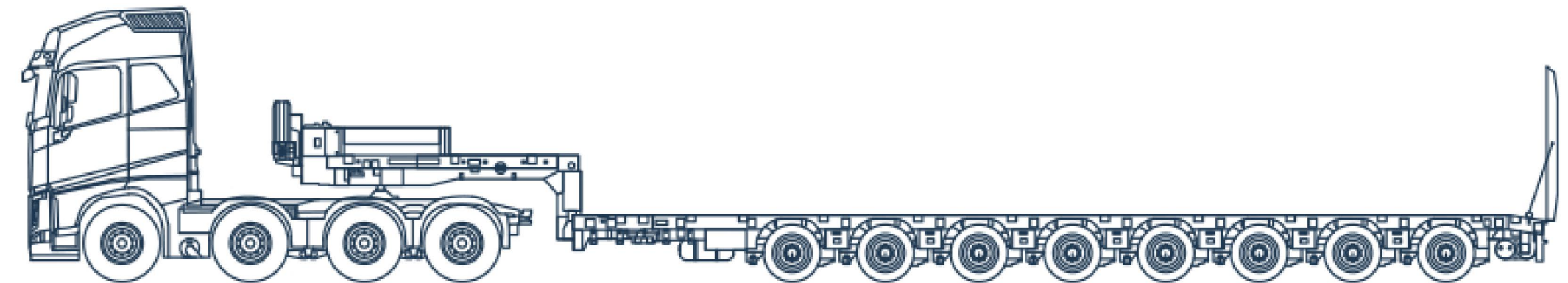

8-axle lowboy trailer

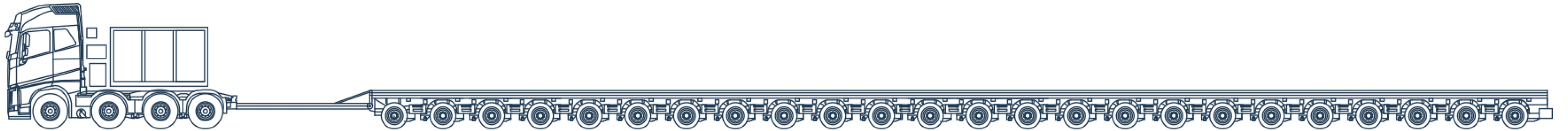

Ballast tractor and 24-axle modular semi-trailer

Structurally, the complex consists of 24 interchangeable modular lines. The adaptive architecture allows for rapid reconfiguration of the road train to suit the specific weight and dimensions of the cargo:

2 sets of 6 lines — for distributed heavy loads.

3 sets of 4 lines — for the simultaneous transport of multiple objects.

Single platform (up to 24 lines) — for super-heavy indivisible structures.

GEOGRAPHY AND COMPLEXITY: OUR EXPERIENCE IN CASE STUDIES



PROJECT «TALIMARJAN POWER STATION»

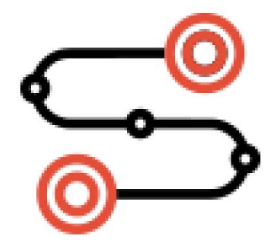

KHORGOS (CN)

⊙ --- 1670 km ---->

TALIMARJAN (UZ)

- 106 t – 6 units – 29300×3900×4100 mm
- 180 t – 3 units – 29300×3900×4100 mm
- 240 t – 3 units – 29300×3900×4100 mm
- 258 t – 6 units – 29300×3900×4100 mm



Watch project video



KHORGOS (CN) - TALIMARJAN (UZ)

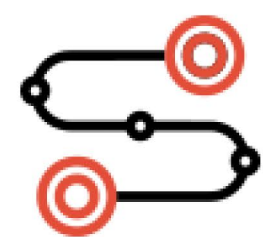

KHORGOS (CN)
 ⓪ --- 1670 km --->
TALIMARJAN (UZ)

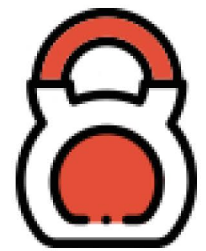

37 135 kg

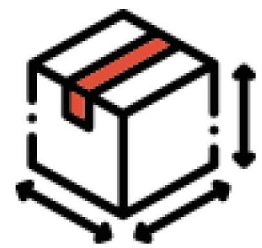

10830×7800×3400 mm



Watch project video



PROJECT «ZOOMLION»



KHORGOS (CN)
⊙ --- 5300 km --->
RF, BELARUS

**173 VEHICLE UNITS DEPLOYED:
LOWBOY TRAILERS AND
OPEN FLATBEDS.**

Watch project video

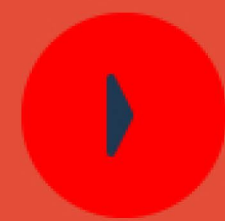



PROJECT «ZOOMLION»



KHORGOS (CN)
⊙ --- 5300 km --->
RF, BELARUS

**173 VEHICLE UNITS DEPLOYED:
LOWBOY TRAILERS AND
OPEN FLATBEDS.**

Watch project video

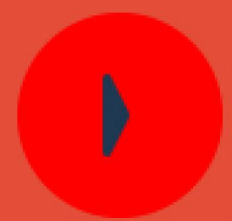

ITEM NAME	WEIGHT (t)	DIMENSIONS (LXWXH) (mm)	QUANTITY
ZOOMLION ZE 215 E	21,5	9600 × 2800 × 3100	113
ZOOMLION ZE 245 E	24	9775 × 3190 × 3285	5
ZOOMLION ZE 155 E	14,5	8000 × 2700 × 3100	4
ZOOMLION ZE 330 E-10	32	11 000 × 2800 × 3000	1
ZOOMLION ZE 370 E	34,6	11 268 × 3190 × 3500	14
ZOOMLION ZE 335 E	31,5	11 200 × 3200 × 3400	5
ZOOMLION ZE 370 EPRO	34,6	11 268 × 3190 × 3500	4
ZOOMLION ZE 245 EPRO	24	9 775 × 3190 × 3285	15
ZOOMLION ZE 135 E -10	14	8 100 × 2500 × 2900	11
ZOOMLION OFF-HIGHWAY DUMP TRUCK ZT188	35	16 400 × 4200 × 3900	1

PROJECT «RNK»



Regular supply chain management for the construction of the Russian Stainless Company's (RNK) modern production facility





KHORGOS (CN) – SUKHOI LOG (RF)



65 360 kg

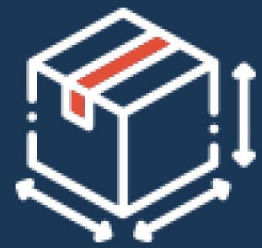

Ø 6800 mm, H-1000 mm



4 800 km

Watch project video

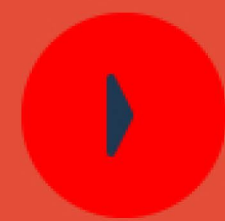

KHORGOS (CN) – BAKU (AZ)

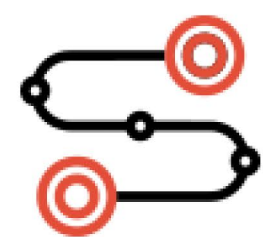

KHORGOS (CN)
⊙ --- 4 400 km --->
BAKU (AZ)

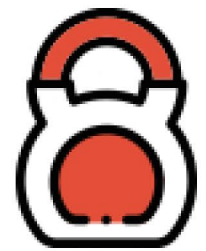

63 550 kg

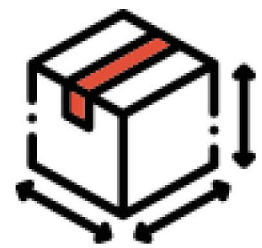

18800×3500×3850 mm



KHORGOS — NIZHNEKAMSK

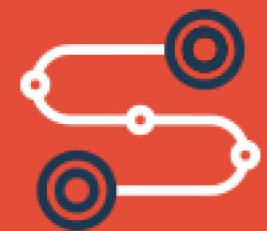

KHORGOS (CN)
 ○ --- 3420 km --->
NIZHNEKAMSK (RF)



Cargo weight:
 up to 75.5 t | Single unit

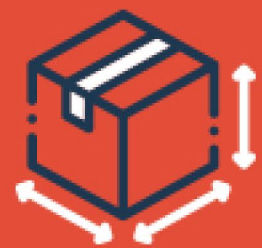

length range: from 11 to 27 meters
width range: from 3.2 to 5.4 meters
height range: from 2.9 to 4.6 meters

Comprehensive project cargo logistics (chillers, receivers, and vessels). We provided end-to-end engineering support: from developing loading schemes and trailer reinforcement to escorting throughout the entire route. All equipment units were delivered to the Nizhnekamsk site precisely on schedule (December 2025 – January 2026).



Watch project video



VOLGOGRAD (RF) – FERGANA (UZ)

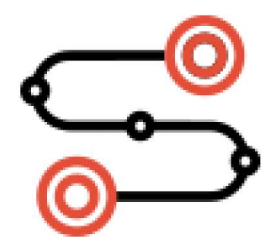

VOLGOGRAD (RF)
⊙ --- 3150 km --->
FERGANA (UZ)



61 000 kg

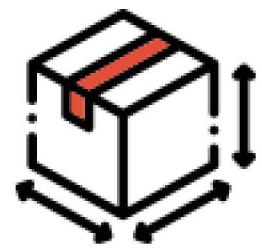

12310×3100×3000 mm





WEIHAI (CN) – VELIKY NOVGOROD (RF)



156 000 kg



12762×5250×4800 mm



9800 km

Organized and executed: a complex international transport of super-heavy, oversized equipment for the chemical industry. Two simultaneous shipments delivered medium-temperature carbon monoxide converters from China to Veliky Novgorod. Destination: a major chemical production complex.

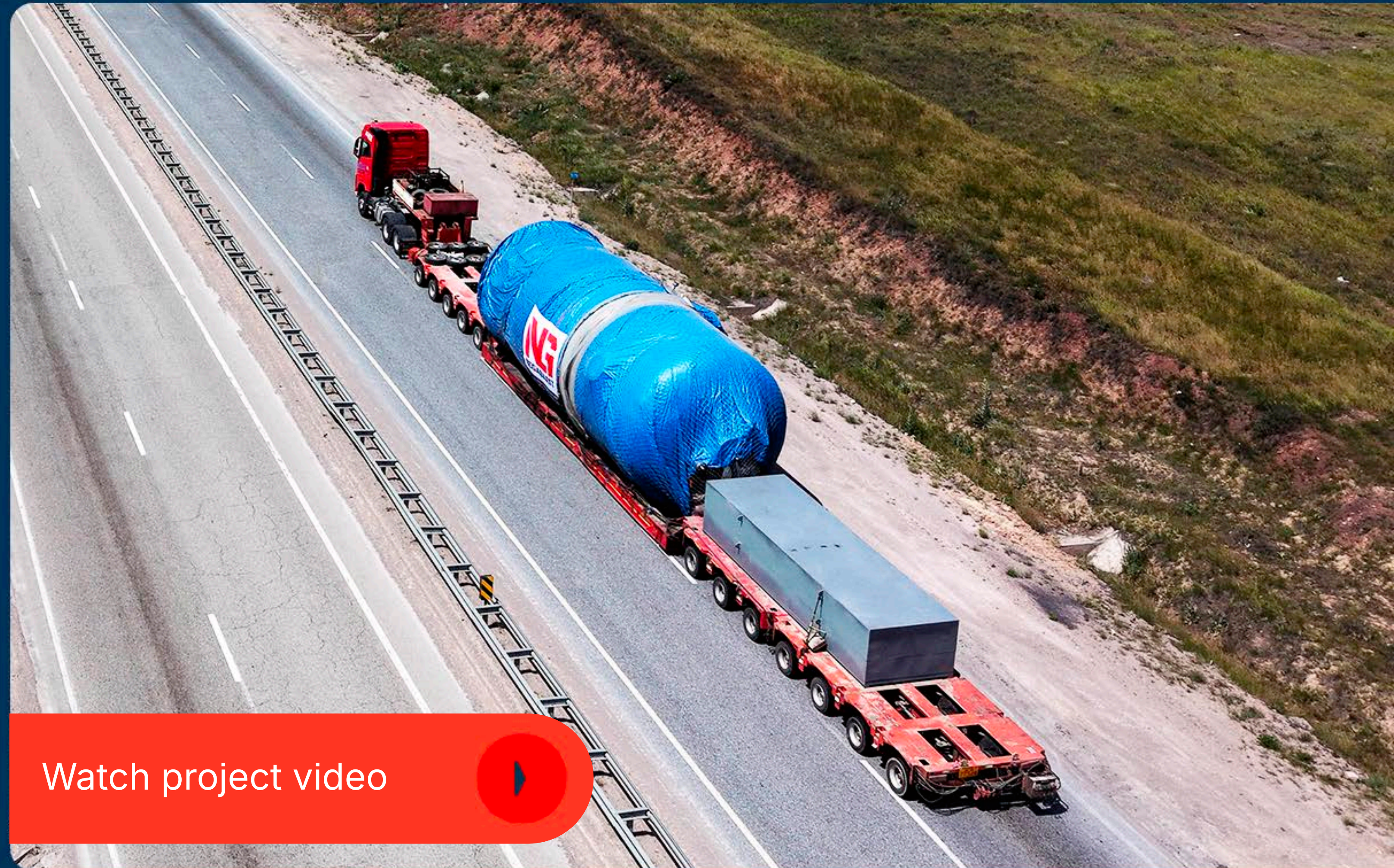

Watch project video



NUR ZHOLY (KZ) – KOVALEVKA, ROSTOV REGION. (RF)

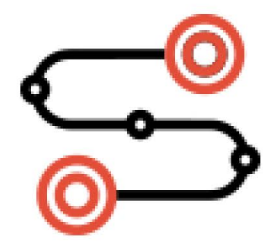

NUR ZHOLY (KZ)
⊙---4260 km---→
KOVALEVKA (RF)

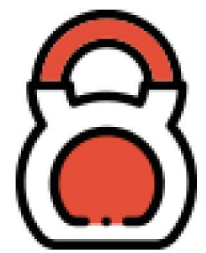

37 700 kg

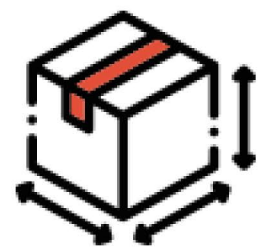

6000×3100×3600 mm





2026

ANSHAN - ST. PETERSBURG

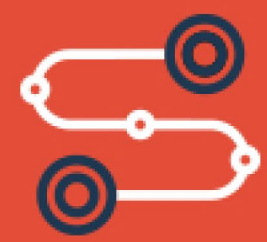

ANSHAN (CN)
○---8700 km--->
SAINT PETERSBURG (RF)



44 500 kg



14000×6000×2000 mm

Watch project video



OUR EXPERTISE IN ACTION



NG-NEGABARIT actively monitors industry developments and implements best practices. Our participation in the International Exhibition "TransLogistica 2025" in Almaty confirms our commitment to innovation and our status as a market leader.

We do not simply follow trends – we participate in shaping them by presenting our experience and the newest solutions in the field of oversized transport.

By working with us, you choose a partner who is always one step ahead.

NG-NEGABARIT: PARTICIPANT OF "TRANSLOGISTICA 2025" IN ALMATY

Your projects deserve the best. Contact us for a consultation

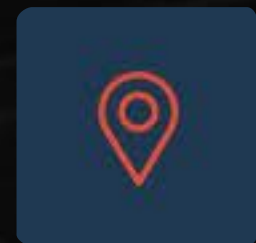

Our address:

RK, Almaty, 98 Zhandosova str., BC "Navoi", Office 306

Our contacts:



+7 (776) 620 0013

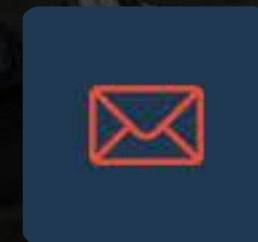

info@ng-negabarit.kz



ng-negabarit.com

Request a quote >



Scan to open the company card